

The logo for Waterfront @Faber is positioned in the bottom right corner. It features the word "Waterfront" in a dark teal, elegant script font. Below it, "@Faber" is written in a smaller, dark teal, sans-serif font. The text is overlaid on a light blue, stylized floral graphic that is part of the overall background pattern.

Waterfront  
@Faber

THE SHINING ALLURE OF CITY VIBRANCY.

## THE BEST OF WORLDS.

This is Waterfront@Faber, the best of worlds – it brings you the bustle of the city – Jurong Lake District opens up before you. It brings you the beauty of nature – Sungei Ulu Pandan adds an idyllic charm. It also positions you right in the middle of two exciting business zones including the One-North high-tech and research corridor. You can start living the life you have always desired. Welcome home.



### LEGEND:

■ ■ ■ ■ ■ Park Connector

For illustration purposes only. Not to scale.



THE HEART OF NATURE.

Approach these natural surroundings with an open mind, and they will open your heart. Mother Nature shares its sublime beauty and gentle guidance to the simple, yet special joys of life, in her classroom of the graceful outdoors. Sungei Ulu Pandan and its accompanying park connector flow alongside the development, designed as a river classroom of flora and floating wetlands, replete with gathering decks of meeting spaces.



THE BEST OF ALL WORLDS.

LIVE AT THE HEART OF LAKESIDE, JURONG GATEWAY, EDUCATION HUB AND ONE-NORTH.

**ONE-NORTH**

**EDUCATION HUB**

**JURONG GATEWAY**

**LAKESIDE**

- BIOPOLIS
- MEDIAPOLIS
- FUSIONOPOLIS
- SCIENCE PARK I & II
- ONE ROCHESTER

- NUS HIGH SCHOOL
- UNIVERSITY TOWN
- UWCSEA
- JAPANESE SCHOOL
- SCHOOL OF SCIENCE & TECHNOLOGY
- INSEAD
- NAN HUA PRIMARY SCHOOL

- JEM
- WESTGATE
- NG TENG FONG GENERAL HOSPITAL
- JURONG COMMUNITY HOSPITAL
- JCUBE
- INTERNATIONAL BUSINESS PARK
- HOTEL
- FUTURE THEME PARK

- NEW SCIENCE CENTRE
- WATER ACTIVITIES
- EDUTAINMENT ATTRACTIONS
- JAPANESE GARDEN
- CHINESE GARDEN

Gutter: 10mm

Artist's Impression

Approximate Locations

## JURONG GATEWAY

Be surrounded by the buzz of Jurong Gateway. The new Central Business District of the West radiates with shining new opportunities. This vibrant commercial hub boasts an excellent mix of shopping, dining, entertainment, medical establishments, offices and more, offering everything you might ever want. The best of city living is waiting for you to harness its potential.



JEM



FUTURE WATERFRONT PARK



INTERNATIONAL BUSINESS PARK



NG TENG FONG GENERAL HOSPITAL



WESTGATE

## LAKESIDE

As one of the biggest regional centres in Singapore, this is a place to fulfil every aspect of life. A major leisure destination for local and international visitors, Jurong Lakeside fills your days with even more excitement. The new Science Centre, waterfront park and promenade with water activities, Lakeside Village and edutainment attractions are just some of the exhilarating highlights.



JURONG LAKE



POSSIBLE FUTURE RAIL



JCUBE



NEW WORLD CLASS SCIENCE CENTRE



FUTURE THEME PARK



FUTURE HOTEL CLUSTER



BIOPOLIS

## ONE-NORTH

One-North is just two stops away by MRT, with all the synergies of Biopolis, Fusionopolis and Mediapolis. Not to mention the Singapore Science Park I & II, the definitive address for research and development in the country.



UNIVERSITY TOWN



FUSIONOPOLIS



MEDIAPOLIS



ONE ROCHESTER



UWCSEA

## EDUCATION HUB

Close to the Education Hub, be surrounded by good schools like NUS, INSEAD, School of Science and Technology, the Japanese School, United World College and Singapore Polytechnic.



NAN HUA PRIMARY



## CHARMING CONTEMPORARY LIVING.

At Waterfront@Faber, charming contemporary living is yours to enjoy every single day. Comprising 7 blocks of 5-storey residences and 11 strata landed homes, the development has been meticulously planned to maximise your enjoyment of life. The accompanying park connector leads to the picturesque Pandan Reservoir, bringing you to the serenity of water.

Gutter: 10mm

Gutter: 10mm





Gutter: 10mm

Gutter: 10mm

HOME SPECTACULAR HOME.





Artist's Impression

# LUXURY RESIDENCES



Endowed with spaciousness, the residences enable owners to design the space according to their own requirements. Flexible furniture decks empower you to maximise the usable space and transform it to your liking. Together with a wealth of facilities, lush landscaping and myriad types of residences to cater to your lifestyle needs, you can now make your dream home come true.



Artist's Impression



Artist's Impression



Enter a forest of luxurious facilities enclosing a magnificent clubhouse that promises a wealth of fine moments, whether it is an intimate gathering of hearts and minds, or a grand function for worthy celebrations. Should you choose to take the festivities outdoors, the Coastal Pavilion takes the fun to a whole new place. After the activities, you may retreat into the lush, soothing embrace of the Forest Spa for some well deserved pampering. In addition, the Sky Park promises a world of activities for your enjoyment. At the Sunrise Terrace, Sunset Terrace and Moonlight Terrace, dining alfresco, strolling leisurely or simply relaxing is always a magical affair.

TIMELESS MOMENTS AWAIT.



Artist's Impression



Artist's Impression



Artist's Impression



Explore a landscape of thematic zones, every one designed to be a fount of new experiences and sweet memories. The Forest teems with the unique Forest Cocoons, chic Creekside Lounge, relaxing Bubble Massage Spa and an undulating Forest Trail. The Lake harbours a cosy Alcove Spa, shaded Lake Cabanas and a majestic Lake Fountain. The Coast encompasses a rejuvenating Isle Spa, meditative Ripple Pool and Puddles Playpool for the little ones. Last but not least is The Valley, which encloses an exciting Kids Adventure playground, serene Valley Patio and Jogging Trail to keep you in the pink of health.

SWEET MEMORIES ABOUND.





Gutter: 10mm

Gutter: 10mm

A STAGE FOR MAGNIFICENT LIVING.

Artist's Impression



EXCLUSIVE STRATA HOMES



Gutter: 10mm

Gutter: 10mm

Fold-In Left: 287(W) x 280(H)mm

SITE PLAN



LEGEND

ARRIVAL BAY

- (1) Drop-off Porch
- (2) Terrace Lounge
- (3) Guardhouse
- (4) BBQ Pavilion

THE FOREST

- (5) Grove Pavilion
- (6) Grove Spa
- (7) Reflective Pond
- (8) Forest Cocoon
- (9) Creek Side Lounge
- (10) Bubble Massage Spa
- (11) Cosy Spa
- (12) Cold Spa
- (13) Forest Trail
- (14) Reflexology Yard

THE COAST

- (15) Isle Spa
- (16) Ripple Pool
- (17) Splash Corner
- (18) Puddles Playpool
- (19) Coastal Pavilion

THE LAKE

- (20) 50m Lap Pool
- (21) Hydrotherapy Deck
- (22) Alcove Spa
- (23) Lakeside Deck
- (24) Lagoon Deck
- (25) Lakeside Bar
- (26) Cove Deck
- (27) Green Deck
- (28) Lake Cabanas
- (29) Green Lounge

THE CLUBHOUSE

- (30) Boston Room
- (31) Staghorn Room
- (32) Victoria Room
- (33) Fitness Gymnasium
- (34) Toilets & Changing Room

THE VALLEY

- (35) Kids Adventure
- (36) Outdoor Fitness
- (37) Valley Patio
- (38) Reading Pod
- (39) Jogging Trail
- (40) Eco Lounge



# SITE PLAN - SKY PARK FACILITIES

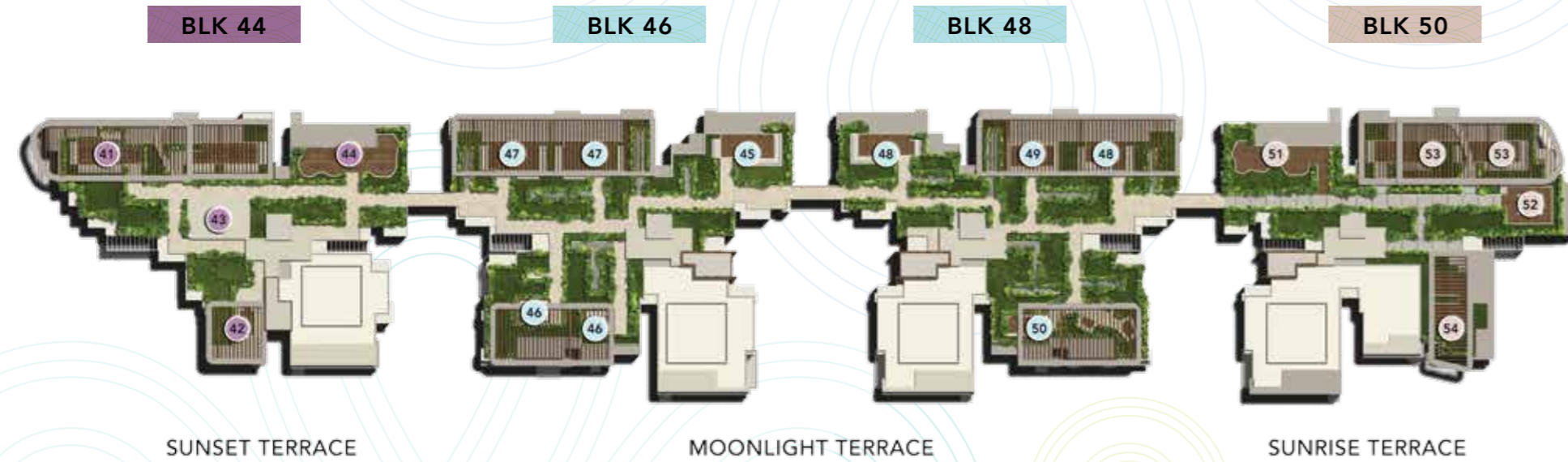

## LEGEND

### SUNSET TERRACE

- (41) River Bonfire
- (42) Meditation Deck
- (43) Gourmet Pavilion
- (44) River Cocoons

### MOONLIGHT TERRACE

- (45) Sky Lounge
- (46) Sky Cabanas
- (47) River Gallery
- (48) Galleria Lounge
- (49) River Yoga Deck
- (50) Moonlight Deck

### SUNRISE TERRACE

- (51) Picnic Garden
- (52) Sunrise Pavilion
- (53) Sky Lounge
- (54) Sunrise Park

# SCHEMATIC DIAGRAM - APARTMENT UNITS

## BLOCK 40

STOREY \ UNIT	01	02	03	04	05	06
05	C1	2DK1	A1	2DK1	C1	B2
04	C1	2DK1	A1	2DK1	C1	B2
03	C1	2DK1	A1	2DK1	C1	B2
02	C1	2DK1	A1	2DK1	C1	B2
01	C1-P		A1-P	2DK1-P	C1-P	B2-P

## BLOCK 42

STOREY \ UNIT	07	08	09	10	11	12	13
05	B2	C1	B1	2DK2	2DK2	B3	A2
04	B2	C1	B1	2DK2	2DK2	B3	A2
03	B2	C1	B1	2DK2	2DK2	B3	A2
02	B2	C1	B1	2DK2	2DK2	B3	A2
01	B2-P	C1-P	B1-P	2DK2-P	2DK2-P	B3-P	A2-P

## BLOCK 44

STOREY \ UNIT	14	15	16	17	18
05	C4	B1	A1	C5	B2
04	C4	B1	A1	C5	B2
03	C4	B1	A1	C5	B2
02	C4	B1	A1	C5	B2
01	C4-P	B1-P	A1-P	C5-P	B2-P

## BLOCK 46

STOREY \ UNIT	19	20	21	22	23	24
05	4DK	B3	2DK3	3DK	C2	B2
04	4DK	B3	2DK3	3DK	C2	B2
03	4DK	B3	2DK3	3DK	C2	B2
02	4DK	B3	2DK3	3DK	C2	B2
01	4DK-P	B4-P	2DK3-P	3DK-P	C2-P	B2-P

## BLOCK 48

STOREY \ UNIT	25	26	27	28	29	30
05	B2	C2	3DK	2DK3	B3	4DK
04	B2	C2	3DK	2DK3	B3	4DK
03	B2	C2	3DK	2DK3	B3	4DK
02	B2	C2	3DK	2DK3	B3	4DK
01	B2-P	C2-P	3DK-P	2DK3-P	B4-P	4DK-P

## BLOCK 50

STOREY \ UNIT	31	32	33	34	35	36
05	B2	C6	A3	A4	B3	C4
04	B2	C6	A3	A4	B3	C4
03	B2	C6	A3	A4	B3	C4
02	B2	C6	A3	A4	B3	C4
01	B2-P	C6-P	A3-P	A4-P	B4-P	C4-P

## BLOCK 52

STOREY \ UNIT	37	38	39	40
05	C3	B3	B3	C3
04	C3	B3	B3	C3
03	C3	B3	B3	C3
02	C3	B3	B3	C3
01	C3-P	B3-P	B3-P	C3-P

## LEGEND

- 2 BEDROOM
- 2 BEDROOM DUAL KEY
- 3 BEDROOM
- 3 BEDROOM (DELUXE)
- 3 BEDROOM DUAL KEY
- 4 BEDROOM
- 4 BEDROOM (DELUXE)
- 4 BEDROOM DUAL KEY



# 3 BEDROOM

## APARTMENT UNITS

### TYPE B1 - P

3 Bedroom + PES  
96 sqm / 1033 sqft  
#01-09  
#01-15

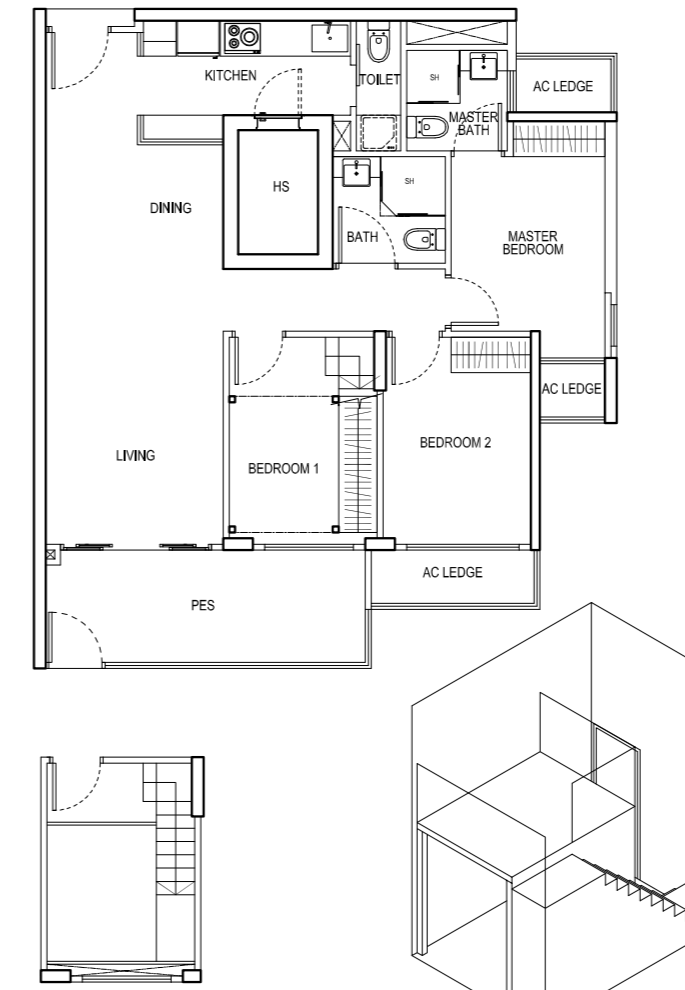

UPPER PLATFORM

AXONOMETRIC

### TYPE B1

3 Bedroom  
96 sqm / 1033 sqft  
#02-09 #02-15  
#03-09 #03-15  
#04-09 #04-15  
#05-09 #05-15

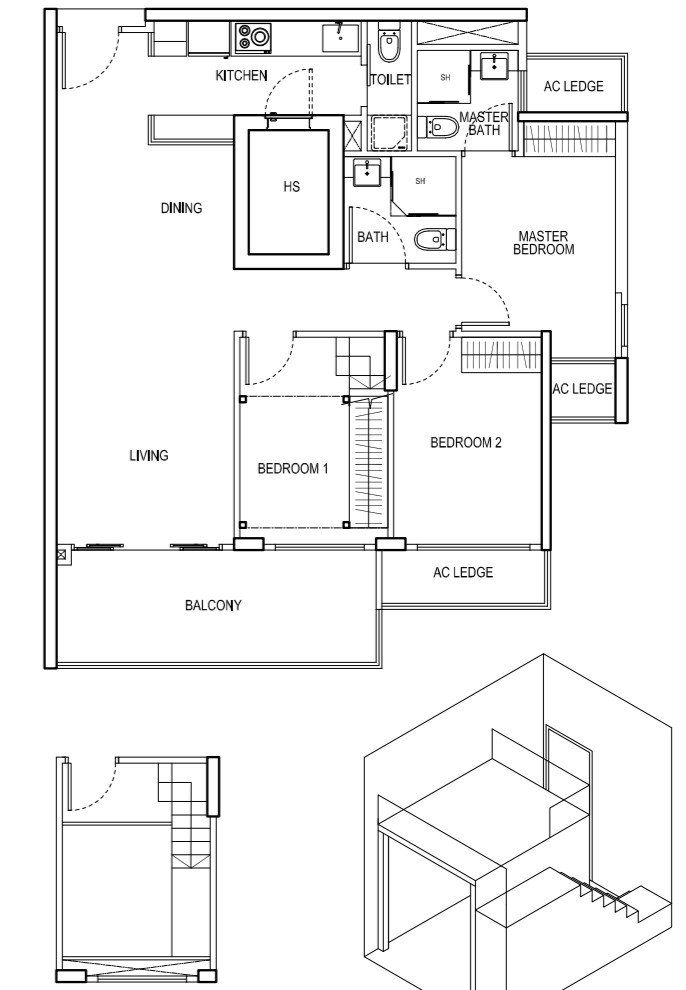

UPPER PLATFORM

AXONOMETRIC

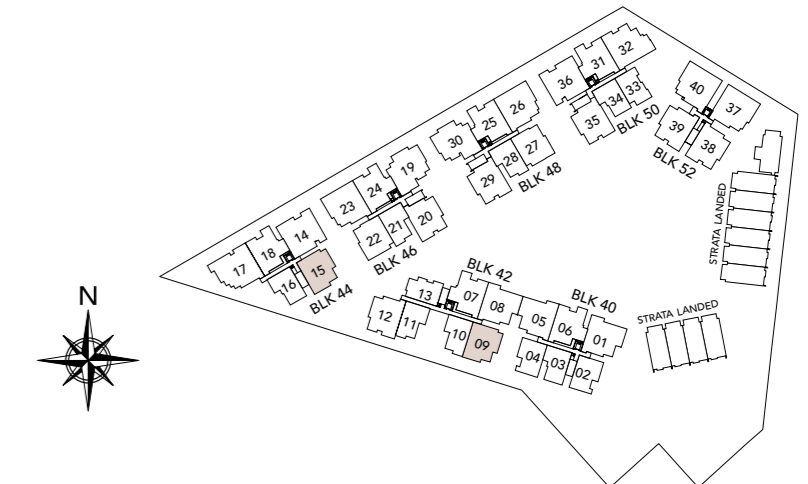

The above plans and illustrations are subject to changes as may be approved by relevant authorities.  
Plans and illustrations are not drawn to scale. The balcony shall not be enclosed. Only approved balcony screen shall be used.

# 3 BEDROOM DELUXE

# 3 BEDROOM DELUXE

## TYPE B2 - P

3 Bedroom Deluxe + PES  
99 sqm / 1066 sqft  
#01-06  
#01-07\*  
#01-18  
#01-24  
#01-25\*  
#01-31\*

\* Mirror Unit

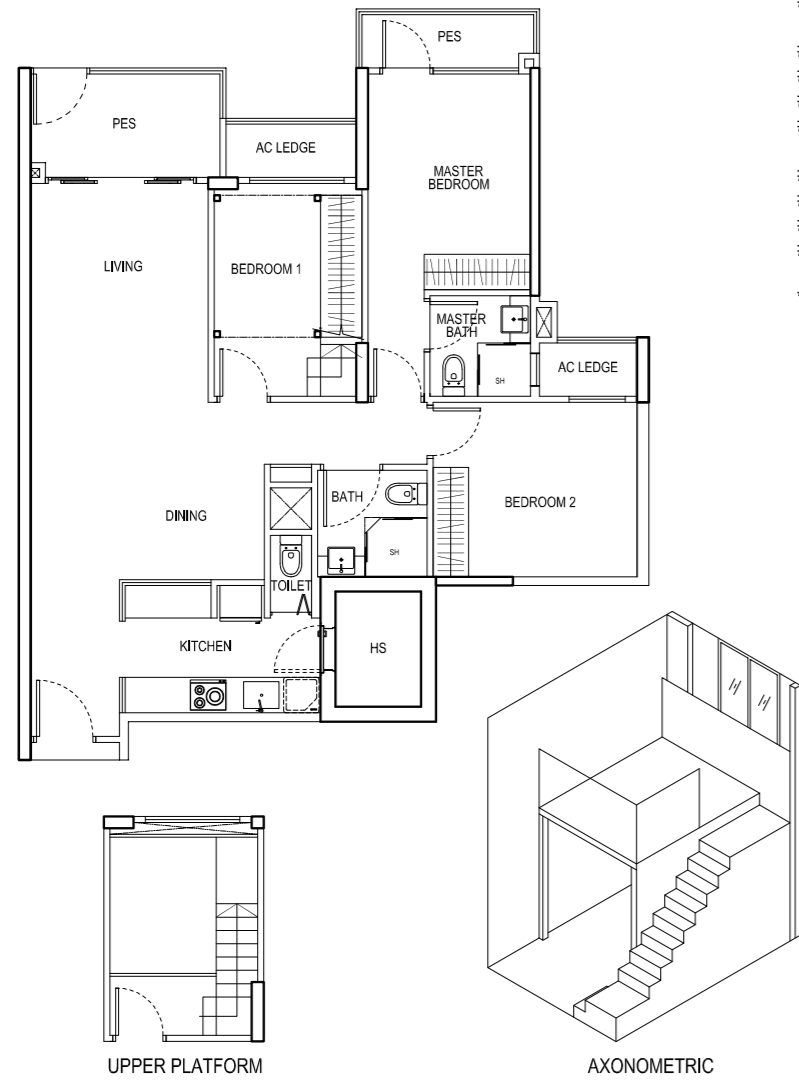

## TYPE B2

3 Bedroom Deluxe  
99 sqm / 1066 sqft  
#02-06 #02-07\*  
#03-06 #03-07\*  
#04-06 #04-07\*  
#05-06 #05-07\*

#02-18 #02-24  
#03-18 #03-24  
#04-18 #04-24  
#05-18 #05-24

#02-25\* #02-31\*  
#03-25\* #03-31\*  
#04-25\* #04-31\*  
#05-25\* #05-31\*

\* Mirror Unit

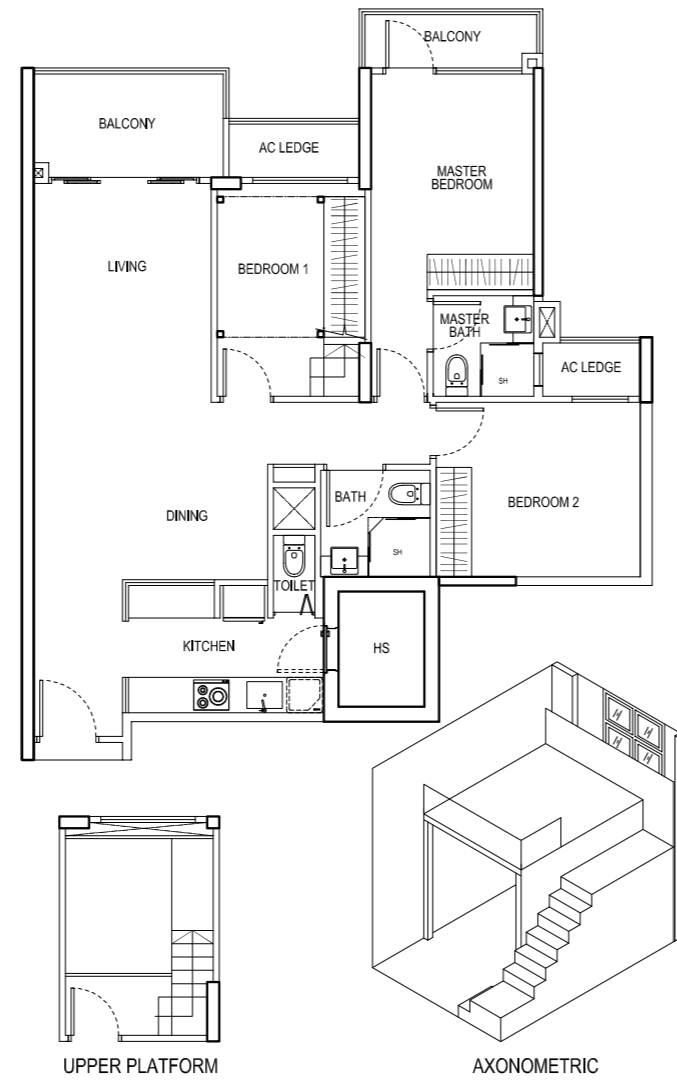

## TYPE B3 - P

3 Bedroom Deluxe + PES  
99 sqm / 1066 sqft  
#01-12  
#01-38\*  
#01-39

\* Mirror Unit

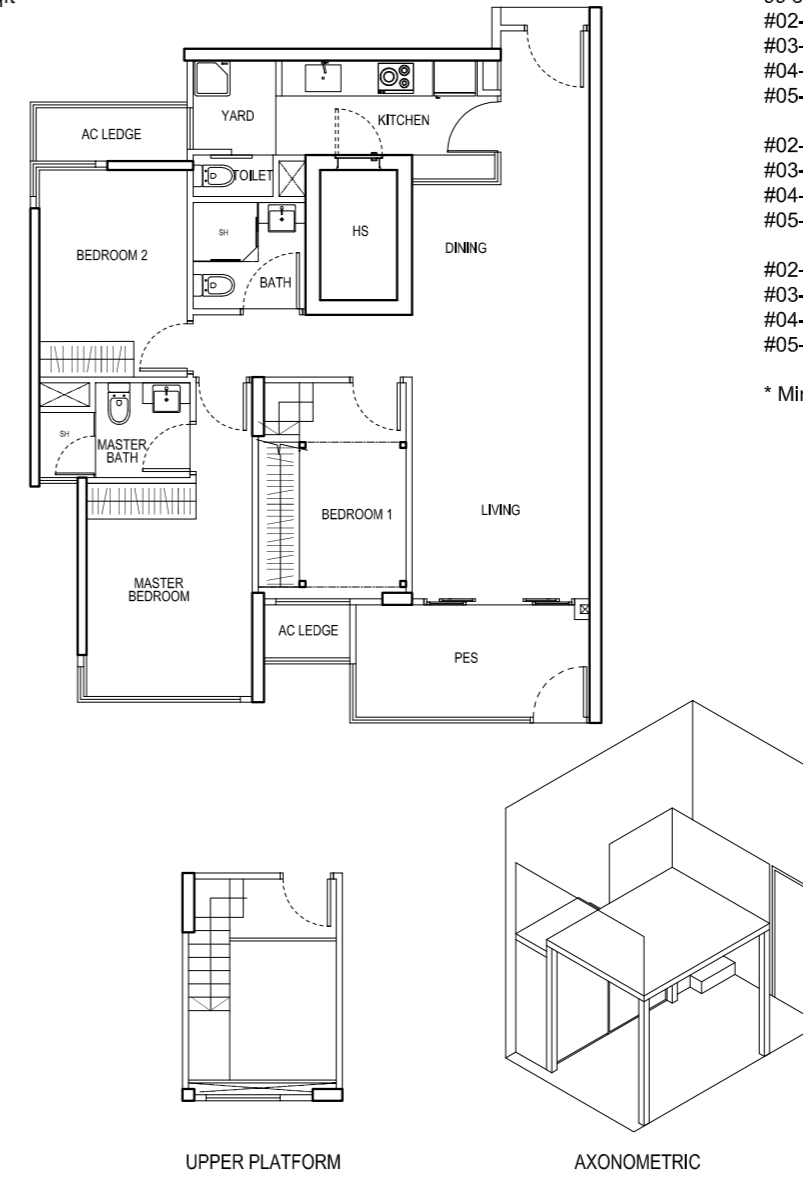

## TYPE B3

3 Bedroom Deluxe  
99 sqm / 1066 sqft  
#02-12 #02-20\*  
#03-12 #03-20\*  
#04-12 #04-20\*  
#05-12 #05-20\*

#02-29 #02-35  
#03-29 #03-35  
#04-29 #04-35  
#05-29 #05-35

#02-38\* #02-39  
#03-38\* #03-39  
#04-38\* #04-39  
#05-38\* #05-39

\* Mirror Unit

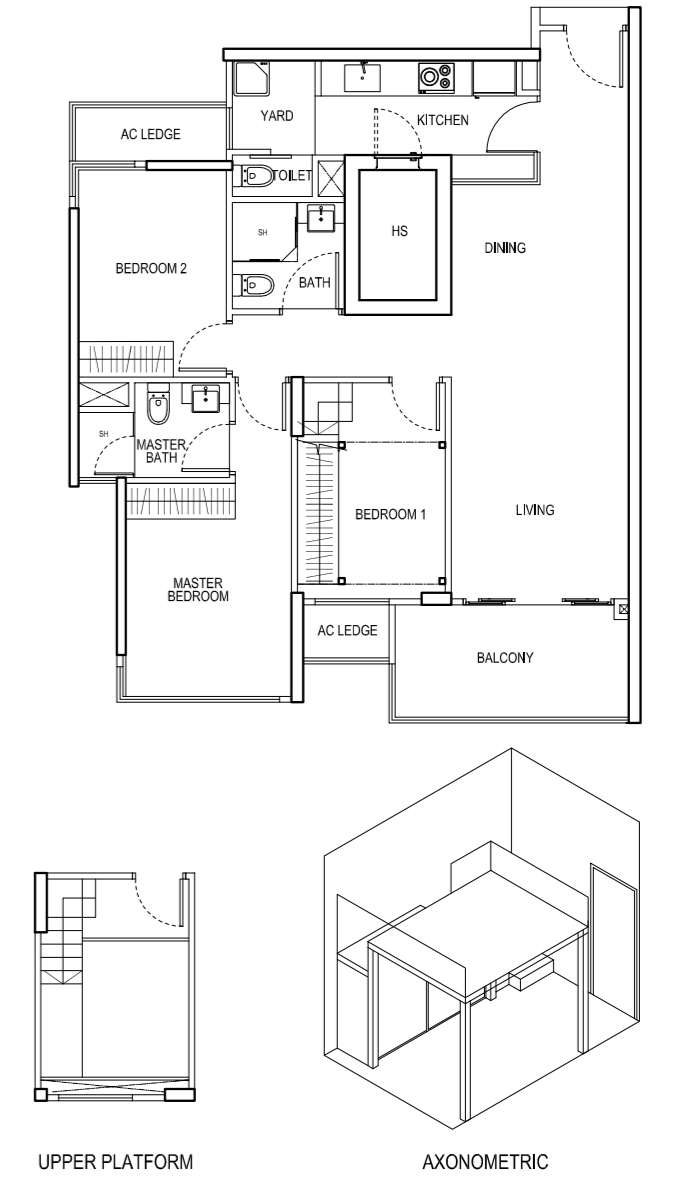

The above plans and illustrations are subject to changes as may be approved by relevant authorities.  
Plans and illustrations are not drawn to scale. The balcony shall not be enclosed. Only approved balcony screen shall be used.

The above plans and illustrations are subject to changes as may be approved by relevant authorities.  
Plans and illustrations are not drawn to scale. The balcony shall not be enclosed. Only approved balcony screen shall be used.

# 3 BEDROOM DELUXE

## TYPE B4 - P

3 Bedroom Deluxe + PES  
 100 sqm / 1076 sqft  
 #01-20\*  
 #01-29  
 #01-35

\* Mirror Unit

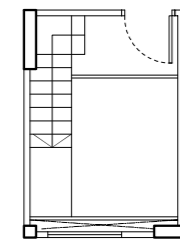
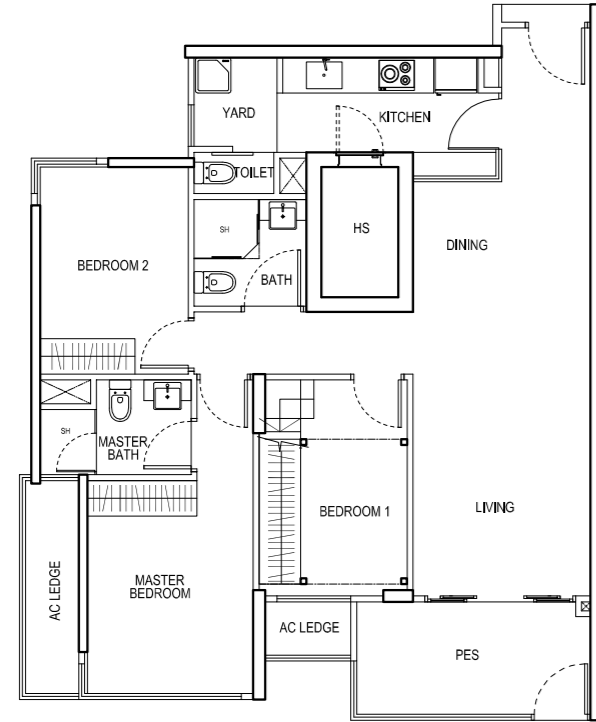

UPPER PLATFORM

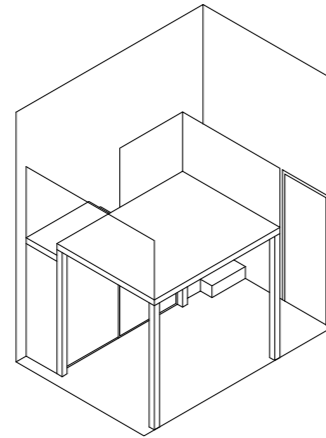

AXONOMETRIC



The above plans and illustrations are subject to changes as may be approved by relevant authorities.  
 Plans and illustrations are not drawn to scale. The balcony shall not be enclosed. Only approved balcony screen shall be used.

# 3 BEDROOM DUAL KEY

## TYPE 3DK - P

3 Bedroom Dual Key + PES  
 95 sqm / 1023 sqft  
 #01-22  
 #01-27\*

\* Mirror Unit

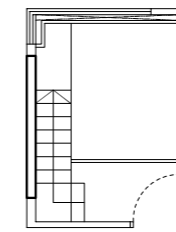
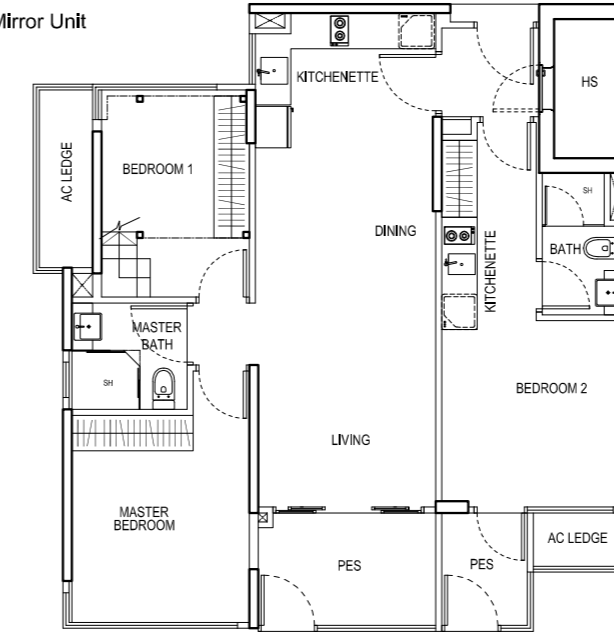

UPPER PLATFORM

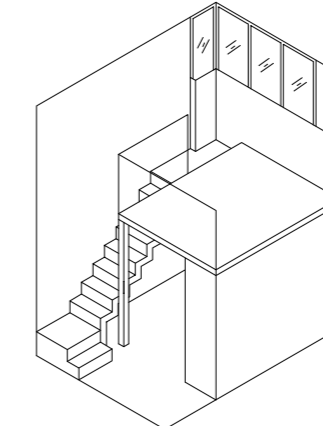

AXONOMETRIC

## TYPE 3DK

3 Bedroom Dual Key  
 95 sqm / 1023 sqft  
 #02-22 #02-27\*  
 #03-22 #03-27\*  
 #04-22 #04-27\*  
 #05-22 #05-27\*

\* Mirror Unit

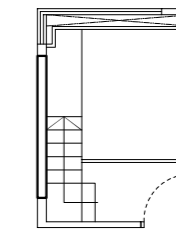
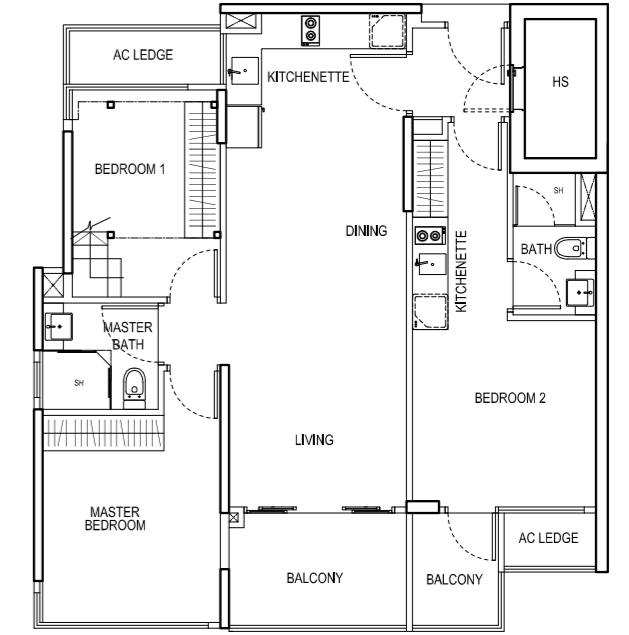

UPPER PLATFORM

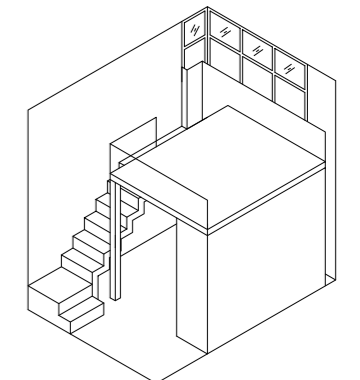

AXONOMETRIC

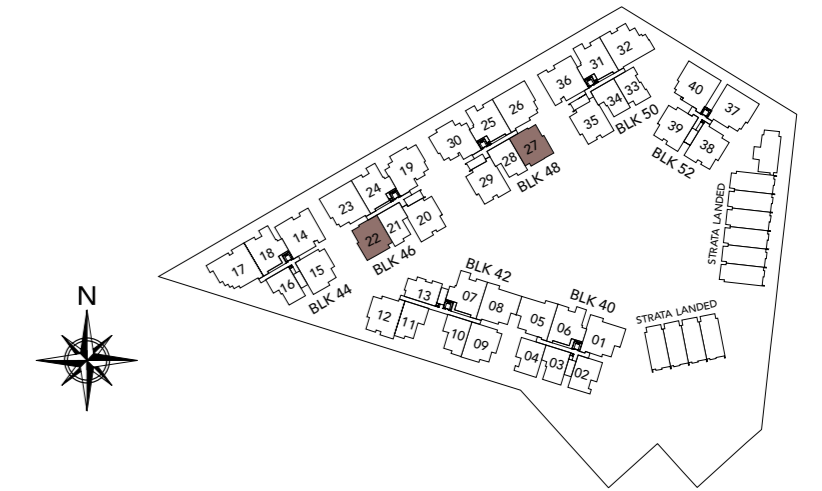

The above plans and illustrations are subject to changes as may be approved by relevant authorities.  
 Plans and illustrations are not drawn to scale. The balcony shall not be enclosed. Only approved balcony screen shall be used.

# 4 BEDROOM

## TYPE C1 - P

4 Bedroom + PES  
109 sqm / 1173 sqft  
#01-01  
#01-05\*  
#01-08

\* Mirror Unit

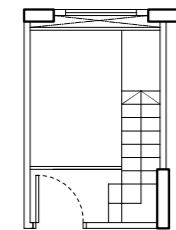
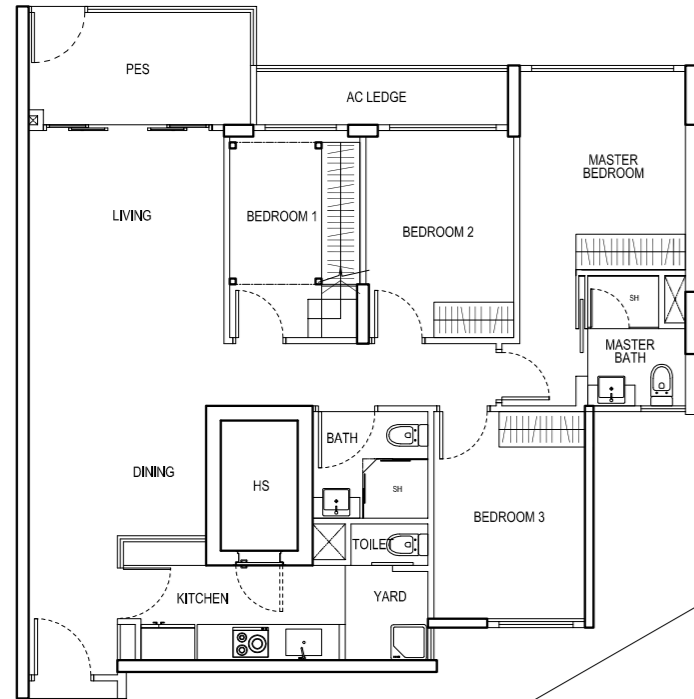

UPPER PLATFORM

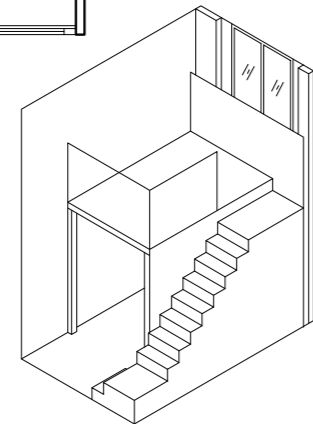

AXONOMETRIC

## TYPE C1

4 Bedroom  
109 sqm / 1173 sqft  
#02-01 #02-05\*  
#03-01 #03-05\*  
#04-01 #04-05\*  
#05-01 #05-05\*

#02-08  
#03-08  
#04-08  
#05-08

\* Mirror Unit

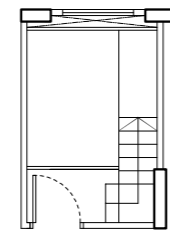
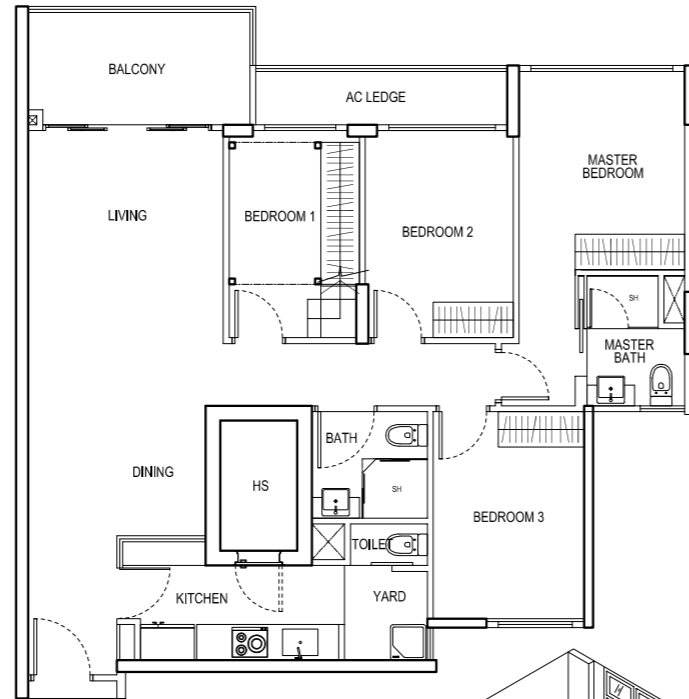

UPPER PLATFORM

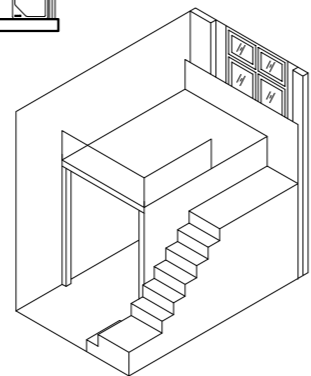

AXONOMETRIC

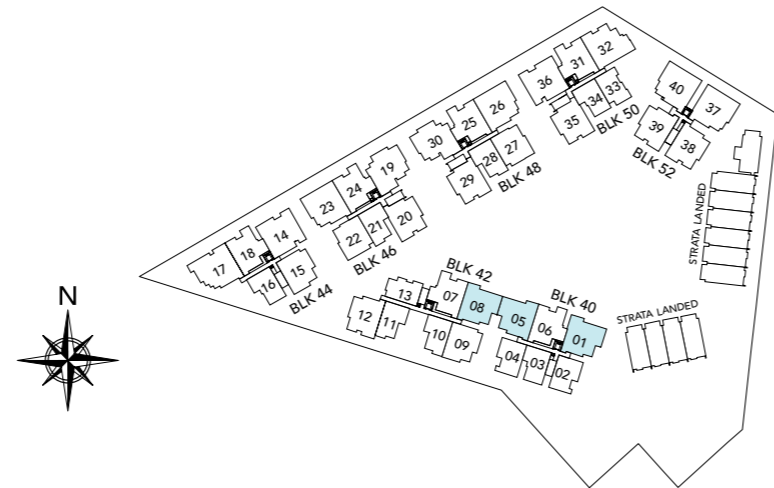

The above plans and illustrations are subject to changes as may be approved by relevant authorities.  
Plans and illustrations are not drawn to scale. The balcony shall not be enclosed. Only approved balcony screen shall be used.

# 4 BEDROOM

## TYPE C2 - P

4 Bedroom + PES  
119 sqm / 1281 sqft  
#01-23  
#01-26\*

\* Mirror Unit

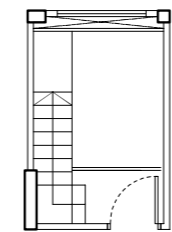
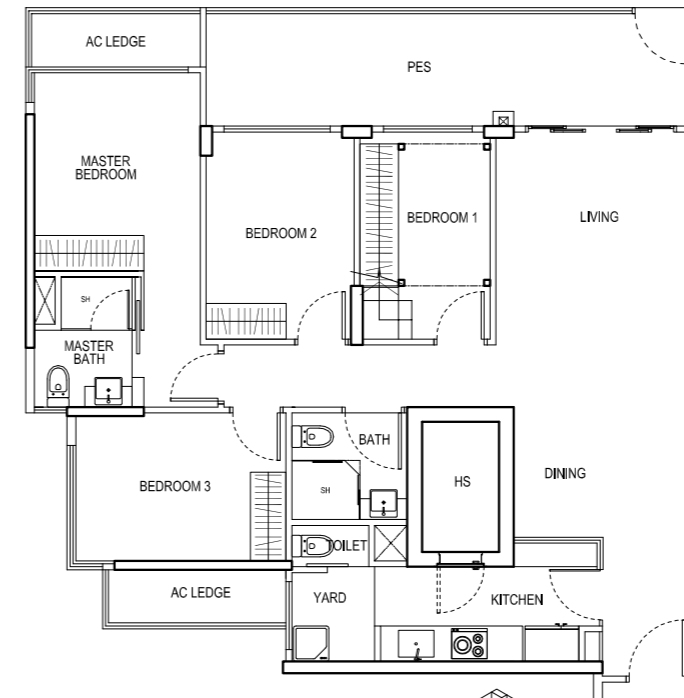

UPPER PLATFORM

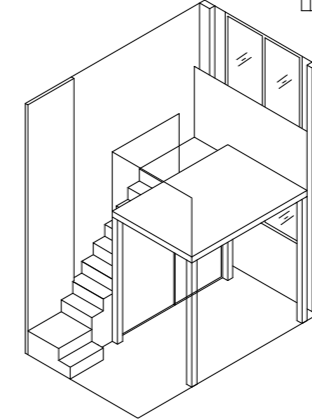

AXONOMETRIC

## TYPE C2

4 Bedroom  
119 sqm / 1281 sqft  
#02-23 #02-26\*  
#03-23 #03-26\*  
#04-23 #04-26\*  
#05-23 #05-26\*

\* Mirror Unit

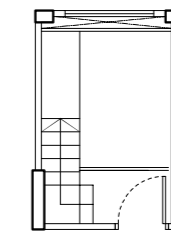
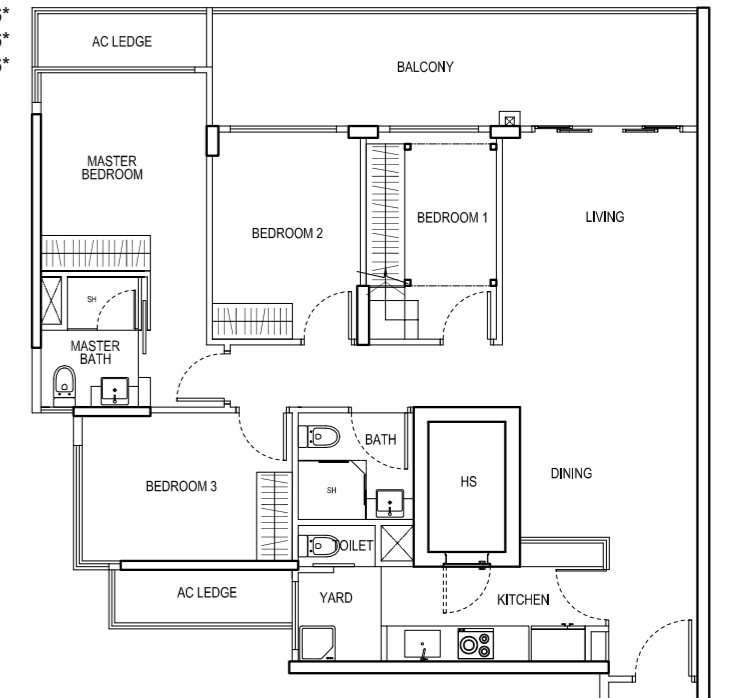

UPPER PLATFORM

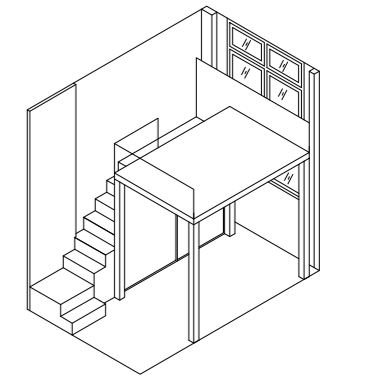

AXONOMETRIC



The above plans and illustrations are subject to changes as may be approved by relevant authorities.  
Plans and illustrations are not drawn to scale. The balcony shall not be enclosed. Only approved balcony screen shall be used.

# 4 BEDROOM

# 4 BEDROOM DELUXE

## TYPE C3 - P

4 Bedroom + PES  
120 sqm / 1292 sqft  
#01-37  
#01-40\*

\* Mirror Unit

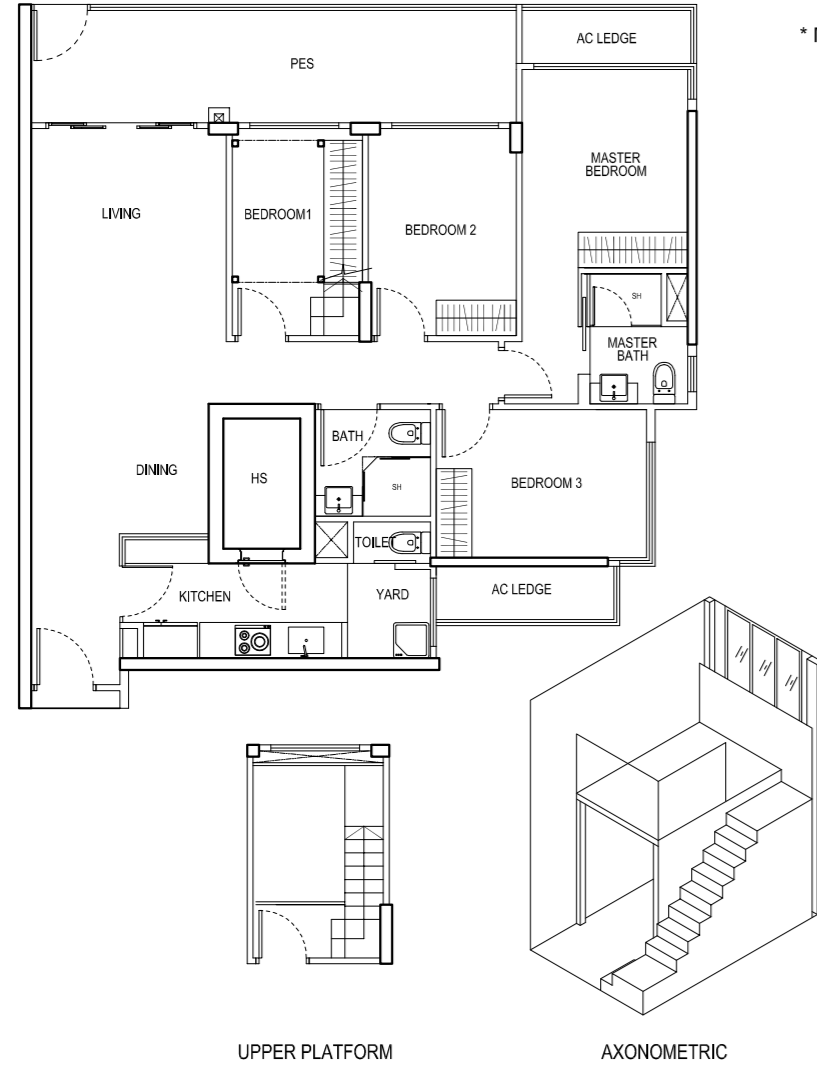

## TYPE C3

4 Bedroom  
120 sqm / 1292 sqft  
#02-37 #02-40\*  
#03-37 #03-40\*  
#04-37 #04-40\*  
#05-37 #05-40\*

\* Mirror Unit

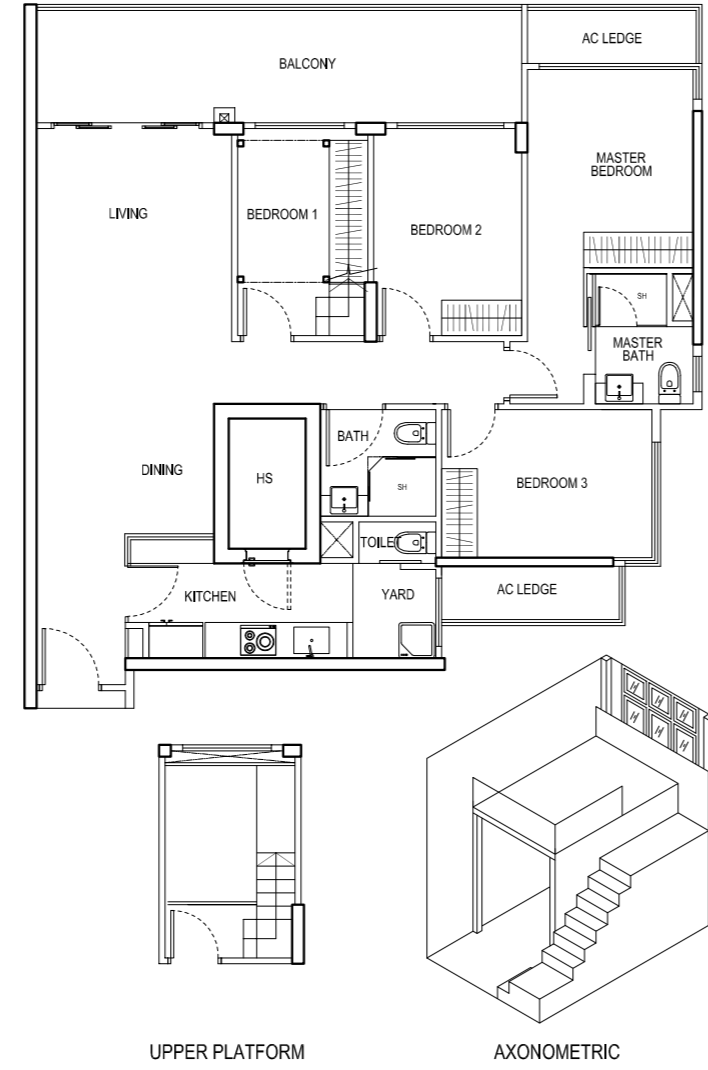

## TYPE C4 - P

4 Bedroom Deluxe + PES  
122 sqm / 1313 sqft  
#01-14  
#01-36\*

\* Mirror Unit

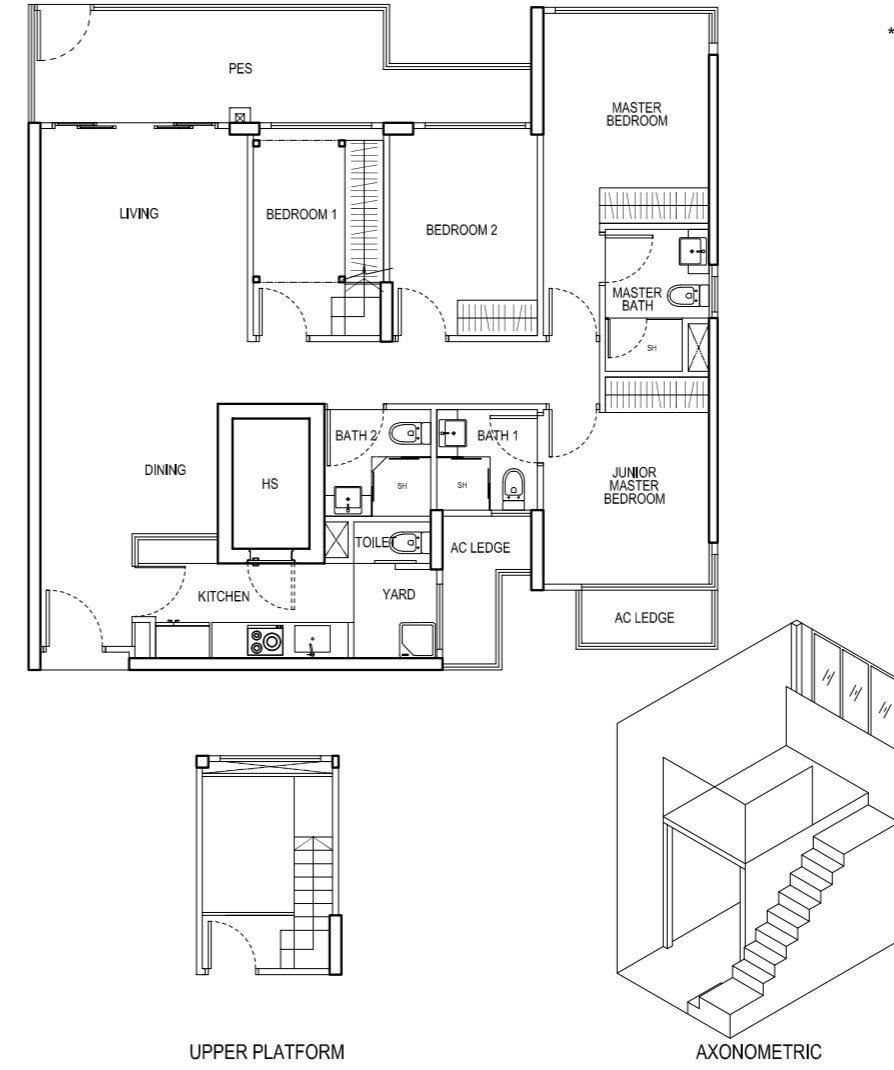

## TYPE C4

4 Bedroom Deluxe  
122 sqm / 1313 sqft  
#02-14 #02-36\*  
#03-14 #03-36\*  
#04-14 #04-36\*  
#05-14 #05-36\*

\* Mirror Unit

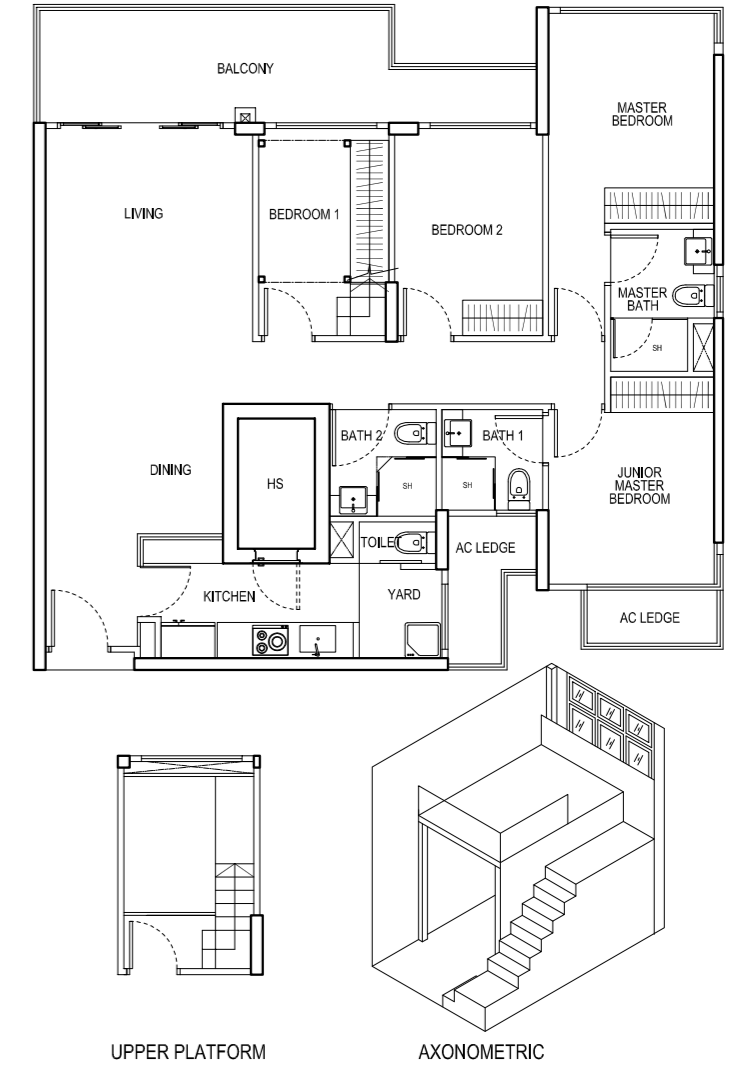

The above plans and illustrations are subject to changes as may be approved by relevant authorities.  
Plans and illustrations are not drawn to scale. The balcony shall not be enclosed. Only approved balcony screen shall be used.

The above plans and illustrations are subject to changes as may be approved by relevant authorities.  
Plans and illustrations are not drawn to scale. The balcony shall not be enclosed. Only approved balcony screen shall be used.

# 4 BEDROOM DELUXE

# 4 BEDROOM DELUXE

## TYPE C5 - P

4 Bedroom Deluxe + PES  
129 sqm / 1389 sqft  
#01-17

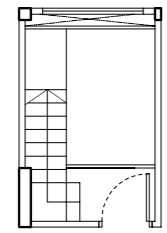
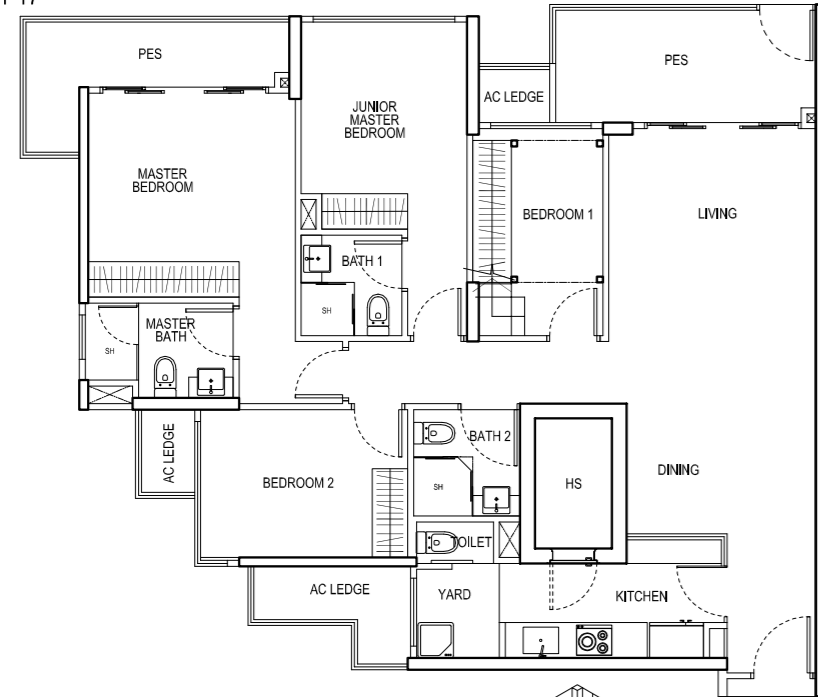

UPPER PLATFORM

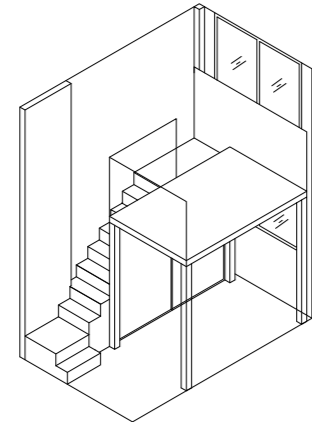

AXONOMETRIC

## TYPE C5

4 Bedroom Deluxe  
129 sqm / 1389 sqft  
#02-17  
#03-17  
#04-17  
#05-17

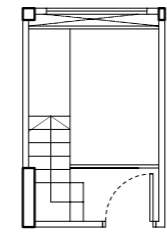
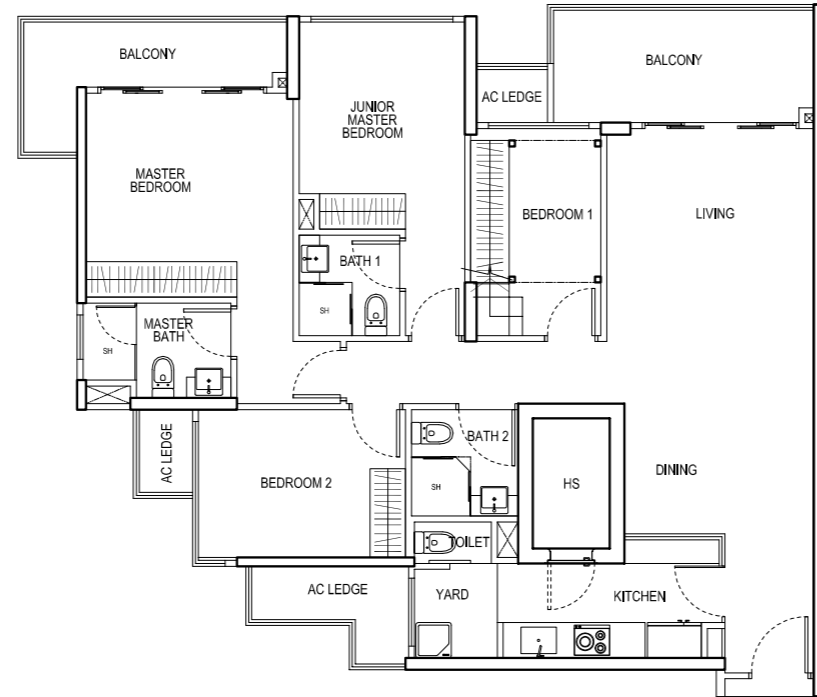

UPPER PLATFORM

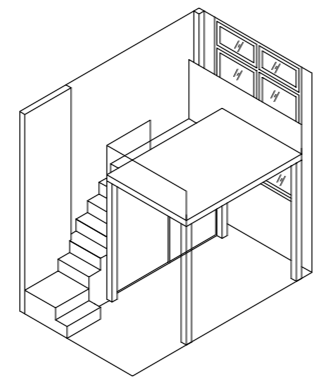

AXONOMETRIC



## TYPE C6 - P

4 Bedroom Deluxe + PES  
123 sqm / 1324 sqft  
#01-32

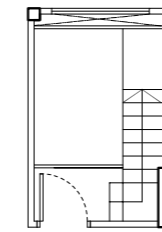
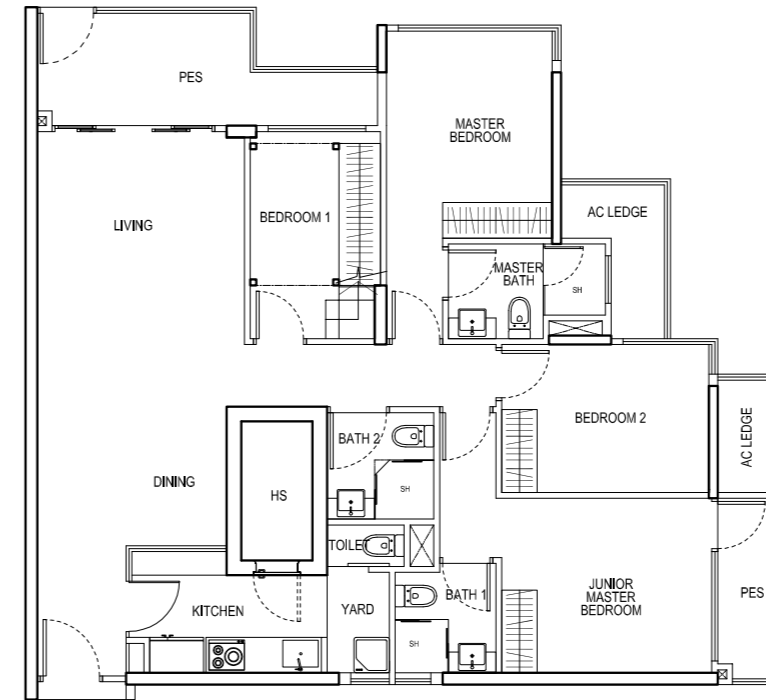

UPPER PLATFORM

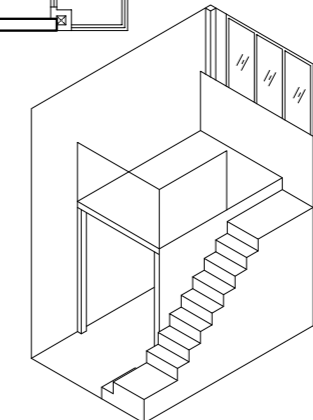

AXONOMETRIC

## TYPE C6

4 Bedroom Deluxe  
123 sqm / 1324 sqft  
#02-32  
#03-32  
#04-32  
#05-32

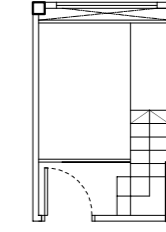
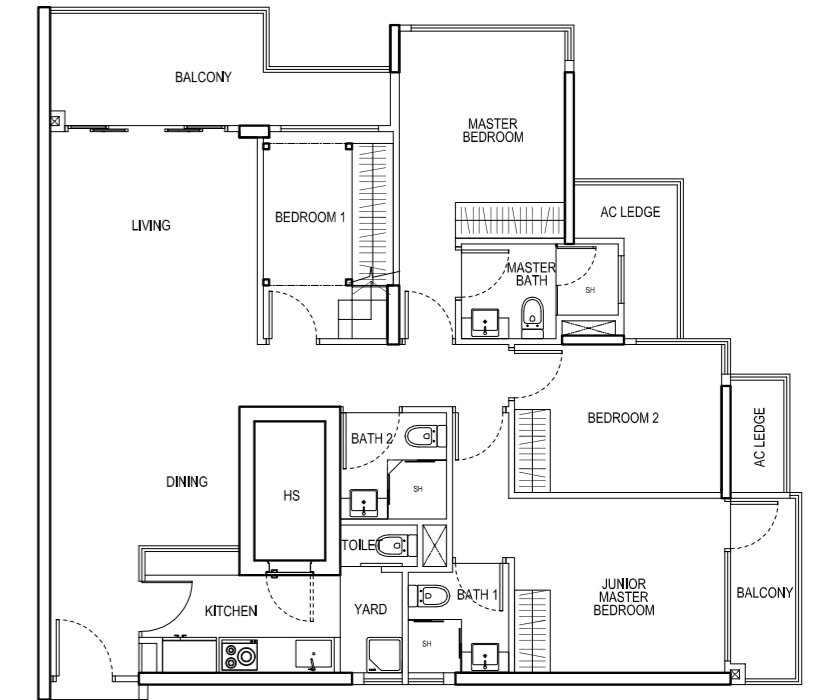

UPPER PLATFORM

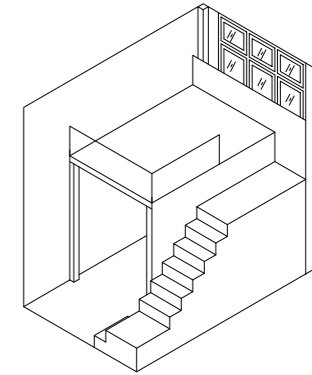

AXONOMETRIC

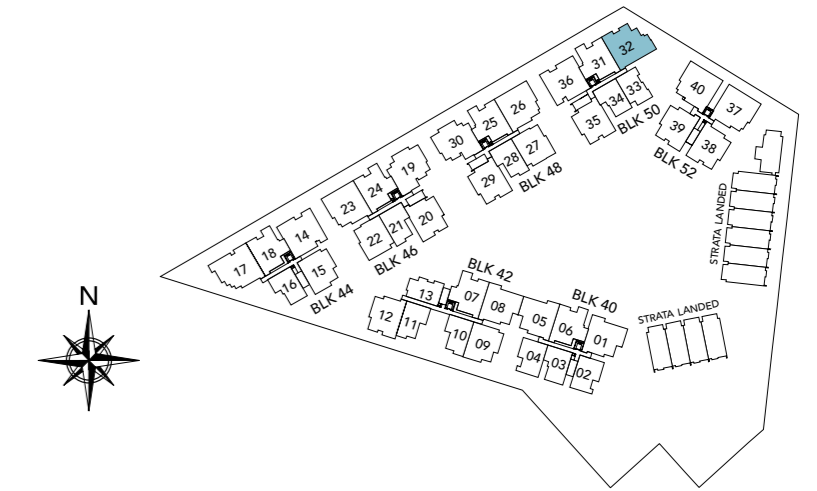

The above plans and illustrations are subject to changes as may be approved by relevant authorities.  
Plans and illustrations are not drawn to scale. The balcony shall not be enclosed. Only approved balcony screen shall be used.

The above plans and illustrations are subject to changes as may be approved by relevant authorities.  
Plans and illustrations are not drawn to scale. The balcony shall not be enclosed. Only approved balcony screen shall be used.

# 4 BEDROOM DUAL KEY

## TYPE 4DK - P

4 Bedroom Dual Key + PES  
 117 sqm / 1259 sqft  
 #01-19  
 #01-30\*

\* Mirror Unit

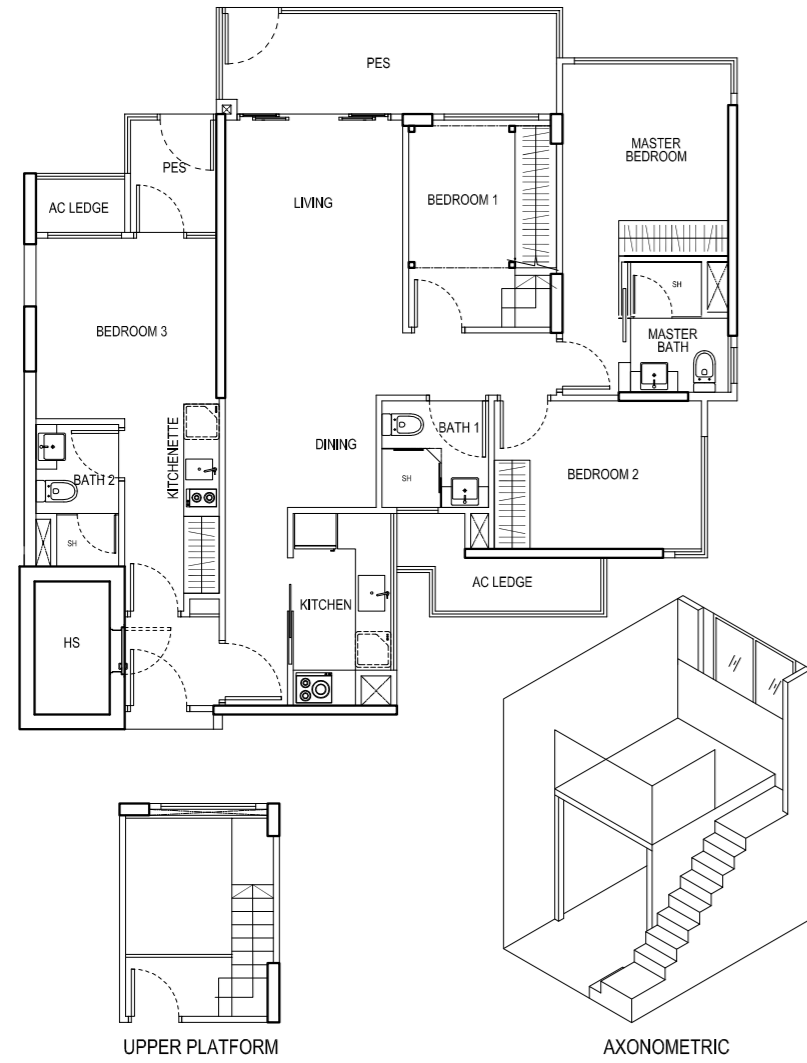

## TYPE 4DK

4 Bedroom Dual Key  
 117 sqm / 1259 sqft  
 #02-19 #02-30\*  
 #03-19 #03-30\*  
 #04-19 #04-30\*  
 #05-19 #05-30\*

\* Mirror Unit

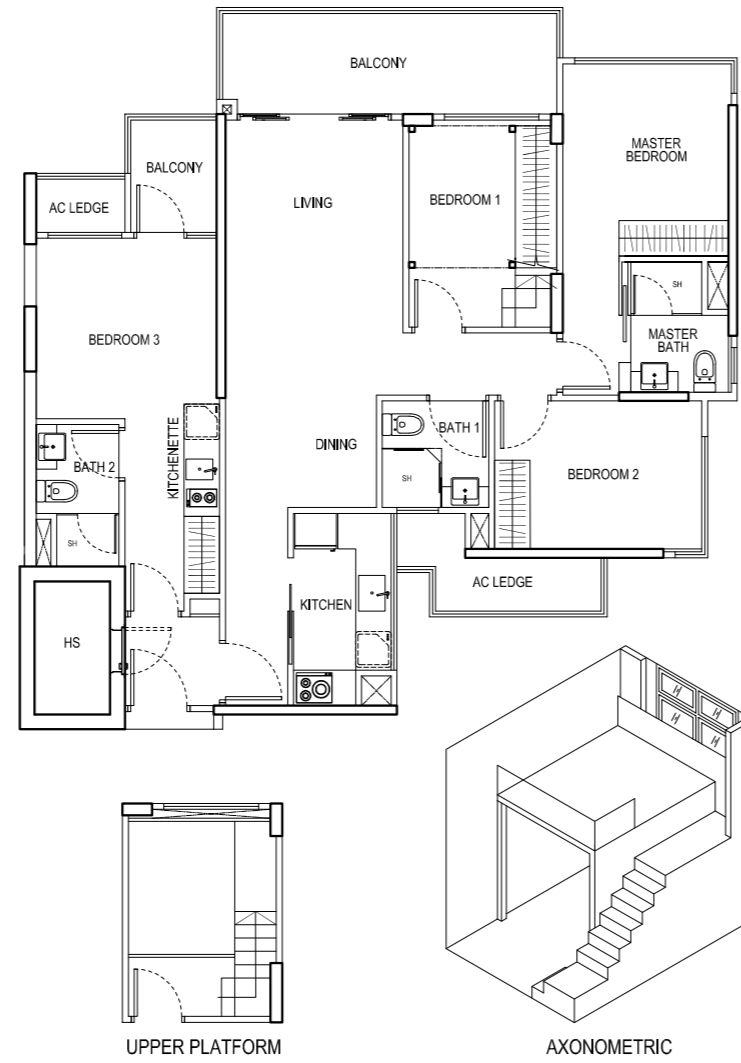

STRATA HOMES

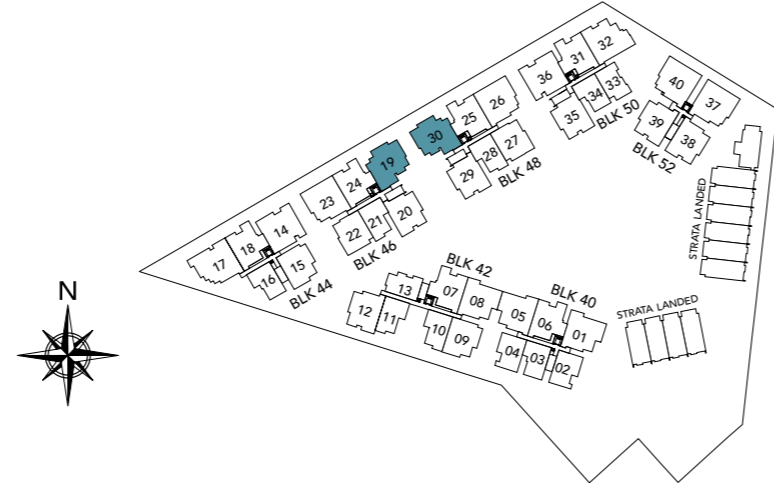

The above plans and illustrations are subject to changes as may be approved by relevant authorities.  
 Plans and illustrations are not drawn to scale. The balcony shall not be enclosed. Only approved balcony screen shall be used.

5 BEDROOM

STRATA HOUSE 1

5 Bedroom Strata House  
298 sqm / 3208 sqft  
No. 18

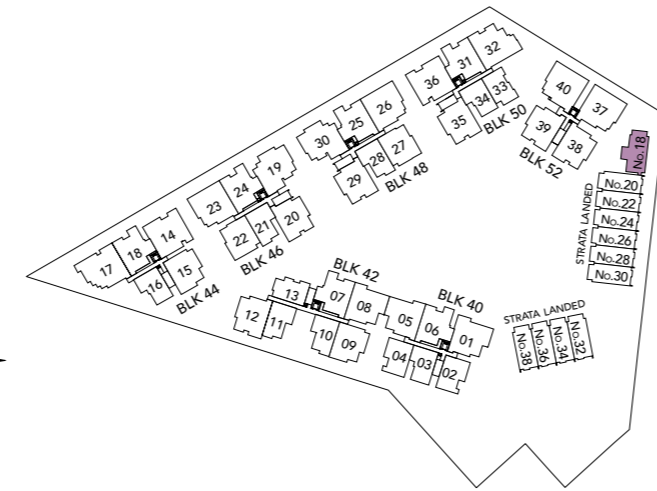
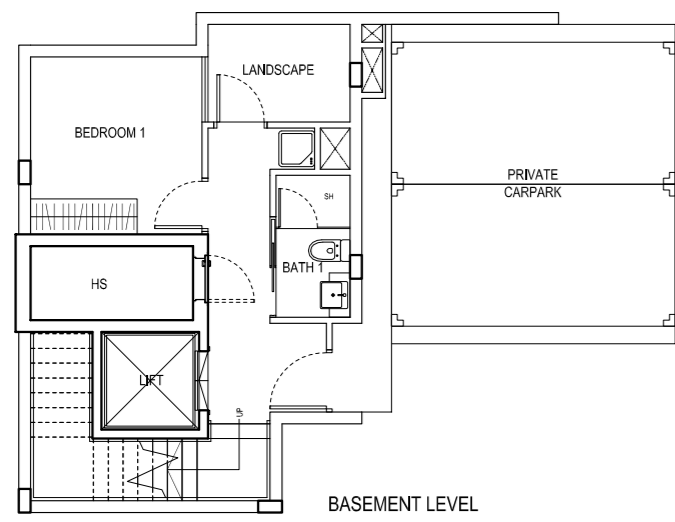
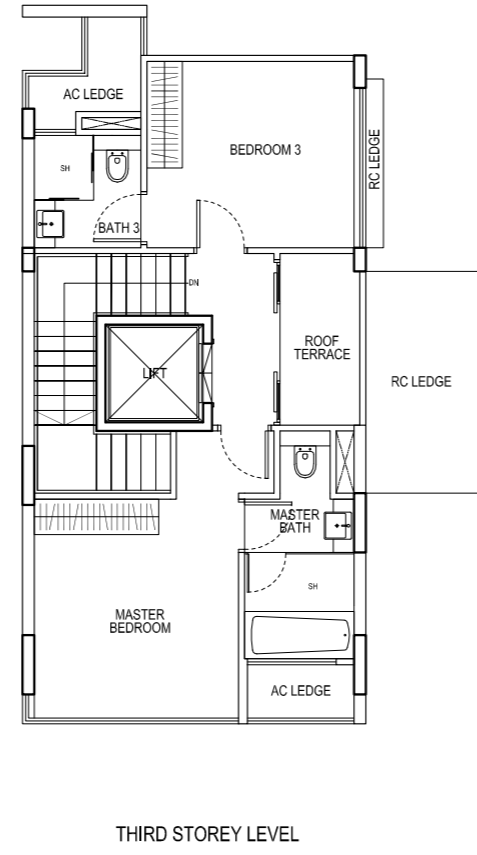
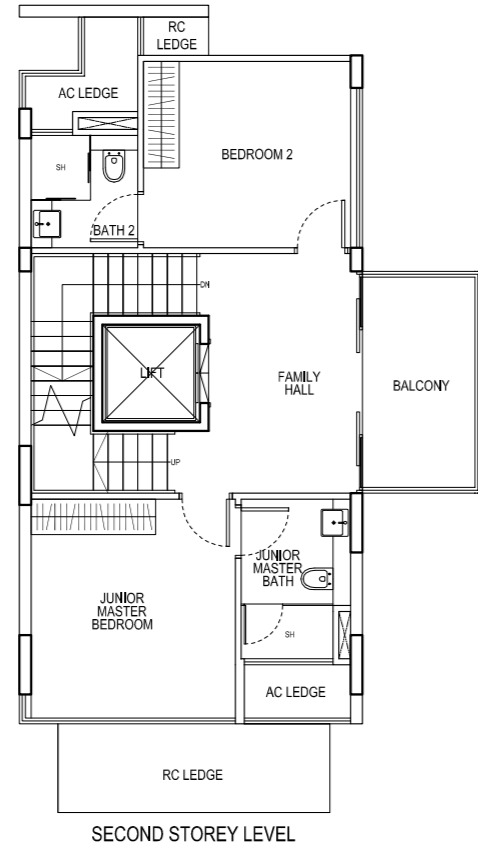
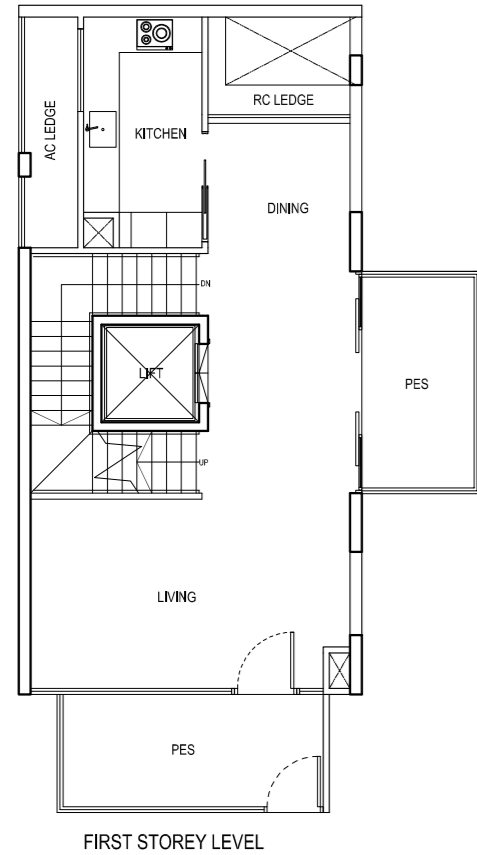

The above plans and illustrations are subject to changes as may be approved by relevant authorities.  
Plans and illustrations are not drawn to scale. The balcony shall not be enclosed. Only approved balcony screen shall be used.

5 BEDROOM

STRATA HOUSE 2

5 Bedroom Strata House  
274 sqm / 2949 sqft  
No. 20\* No. 30\*  
No. 22\* No. 32  
No. 24\* No. 34  
No. 26\* No. 36  
No. 28\* No. 38

\* Mirror Unit

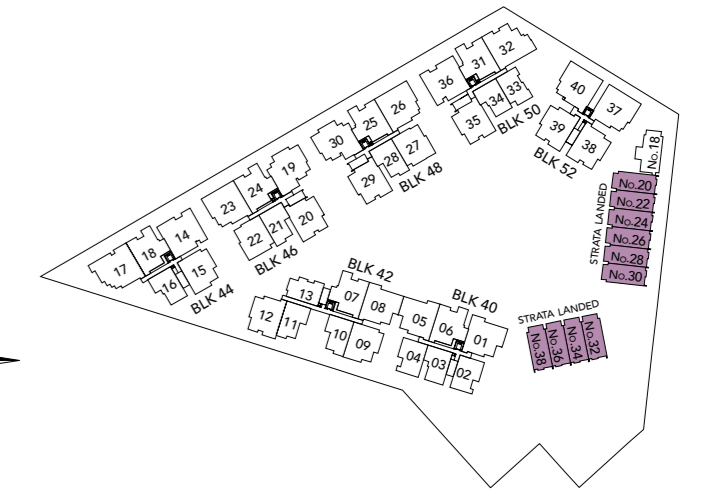
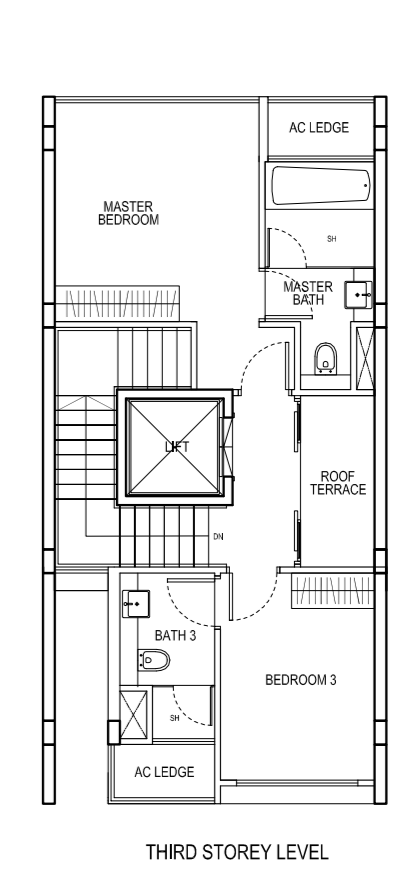
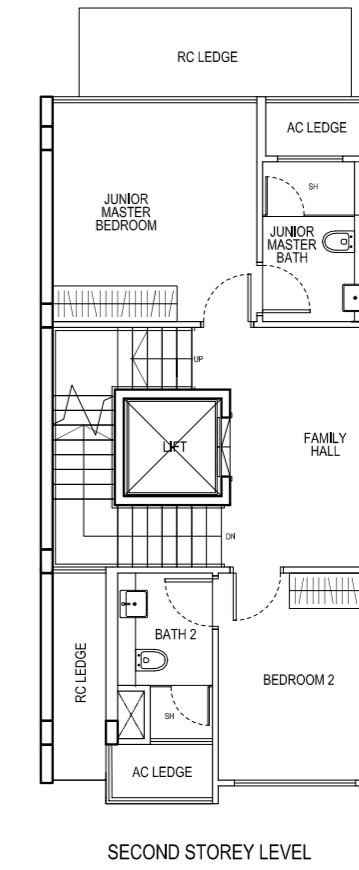
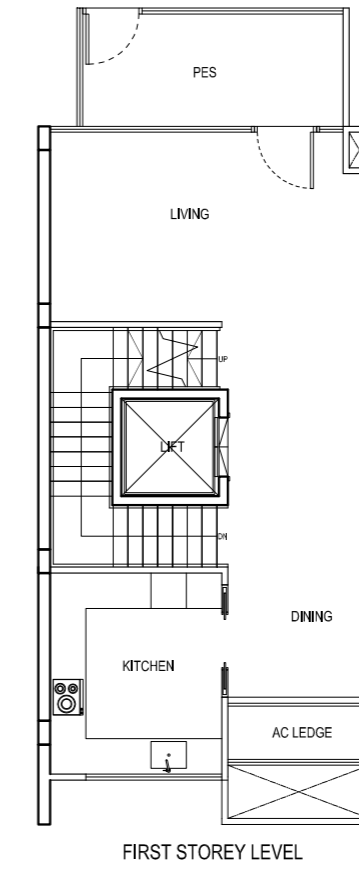
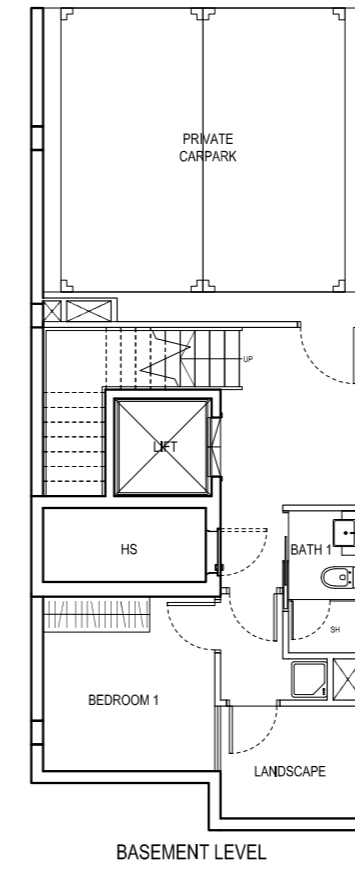

The above plans and illustrations are subject to changes as may be approved by relevant authorities.  
Plans and illustrations are not drawn to scale. The balcony shall not be enclosed. Only approved balcony screen shall be used.



## WORLD CLASS CREDENTIALS

World Class Land is one of the front runners in residential real estate, offering a range of residences from landed housing to luxurious condominium projects. Since its inception in 1999, World Class Land has successfully developed, marketed and managed over 35 small and large-scale projects including landed housing, luxurious condominiums and mixed developments.

Over the years, World Class Land has displayed an innovative and intuitive edge when it comes to understanding the needs and desires of today's homebuyers. This puts it at the forefront of the industry, exploring new project concepts such as The Hillford, Singapore's first retirement resort. It is also stretching its horizons beyond Singapore, expanding overseas to countries such as Australia and Malaysia.





WORLD CLASS LAND

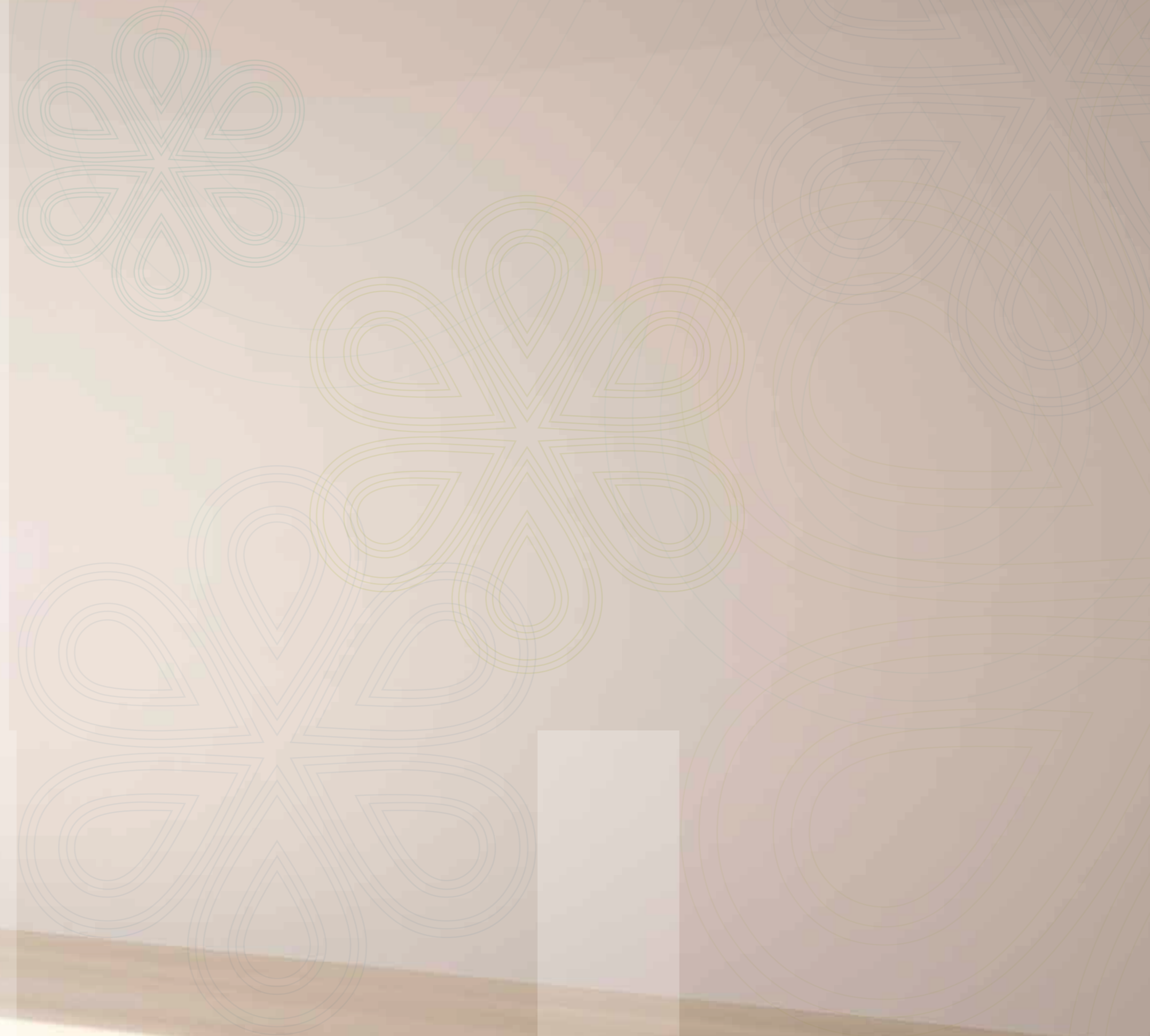

Developer: World Class Land Pte Ltd • Company Reg No: 199906090H • Tenure of Land: 99 years from 17-Sep-13 • Lot No & Mukim No: MK 05 Lot No 08870V • Building Plan: A1716-00007-2013-BP01  
• Approved On: 21-Apr-2014 • Expected TOP Date: 15-Jul-2018 • Expected Date of Legal Completion: 15-Jul-2021 • Developer's License No: C1134.